

SPECIFICATION
FOR
BATTERY, DRY (LECLANCHÉ), 90 V, NO 1 NATO STOCK NO 6135-99-910-1124
(NATO TYPE DESIGNATION NBA 415)

This Supplement supersedes SUPPLEMENT NO 24 to
DEF STAN 61 - 3 (PART 1), dated 19 March 1968

1. This Supplement is to be read in conjunction with the General Specification for primary batteries (Leclanché, mercury, and manganese alkaline types) contained in DEF STAN 61 - 3 (PART 1).
2. NOMINAL VOLTAGE
 - a. Cell.
1.5
 - b. Battery.
90 with tappings at 22.5, 45, and 67.5
3. DIMENSIONS
Dimensions shall be in accordance with the requirements of the attached drawing.
4. MASS
Mass shall not exceed 1 pound 5 ounces (595.35 grams).
5. MARKINGS
Marking shall be in accordance with the requirements of the General Specification contained in DEF STAN 61 - 3 (PART 1), clause 11. and the attached drawing.
6. CONSTRUCTION
 - a. Assembly.
 - (1) Normally 60 layer-type cells connected in series and enclosed in an insulating container.
 - (2) Alternatively, 60 cylindrical cells connected in series and enclosed in an insulating container.
 - (3) Inter-cell connections between cylindrical cells shall be soldered, using wire not thinner than 0.018 in (26 s.w.g.) (0.46 mm).
 - (4) Cell-socket connections when cylindrical cells are used and all internal connections when layer-type cells are used, shall be soldered, using insulated stranded wire.

DEF STAN 61 - 3 (PART 1)
SUPPLEMENT NO 24/2

6. a. (5) When cylindrical cells are used, the whole assembly shall be blocked securely to prevent internal movement.
- (6) The hole in the outer container shall be concentric with the socket and shall be sealed in such a manner that the seal may be removed and replaced effectively to permit testing of the battery during storage.
- (7) After sealing, the battery shall be dipped in micro-crystalline wax at a temperature of not less than 100°C, for not less than five seconds, in such a manner that the battery is covered completely with a smooth and continuous protective wax film.

b. Cell details.

(1) Size.

(a) Layer type: F60 (BS 397).

(b) Cylindrical type: R1 (BS 397).

(2) Zinc thickness for cylindrical type.

Shall be not less than 0.009 in (0.23 mm).

c. Terminations.

Socket 112b in accordance with DEF STAN 59-35 (PART 1), Section 7.

7. STORAGE AND PERFORMANCE TESTS

a. Allocation of sample batteries.

(1) For Qualification Approval testing.

Shall be in accordance with the requirements of the General Specification contained in DEF STAN 61 - 3 (PART 1), clause 6.b.

(2) For Quality Assurance testing.

Number of sample batteries supplied shall be in accordance with the requirements of the General Specification contained in DEF STAN 61 - 3 (PART 1), clause 14.b. and shall be divided between the tests shown in the table below as follows:

10% Jungle with the balance divided equally between the other four types of storage.

7. b. Storage conditions and performance requirements.

TYPE OF STORAGE	GENERAL SPECIFICATION CLAUSE	STORAGE PERIOD (WEEKS)	MINIMUM DISCHARGE LIFE AFTER STORAGE (HOURS)
Temperate (Short term)	17.a.	4	32
Temperate (Long term)	17.a.	52	24
∕ Jungle	17.c.	8	28
∅ Desert	17.b.	26	22
Temperate (Spare)	18.d.	-	-

Notes:

1. ∕ indicates insulation resistance after Jungle storage (General Specification DEF STAN 61 - 3 (PART 1), clause 19.) to be not less than 2 megohms.
2. ∅ indicates batteries stored singly.

c. Discharge test conditions.

(1) Resistance loads.

R1: 5200 ohms.
 R2: 13 200 ohms.

(2) Discharge cycle.

Two minute discharge through R1 followed by 18 minutes discharge through R2, repeated continuously for four hours; followed by 20 hours off-load. This cycle to be repeated on five consecutive days per week.

(3) On-load voltage end-point.

66 volts.

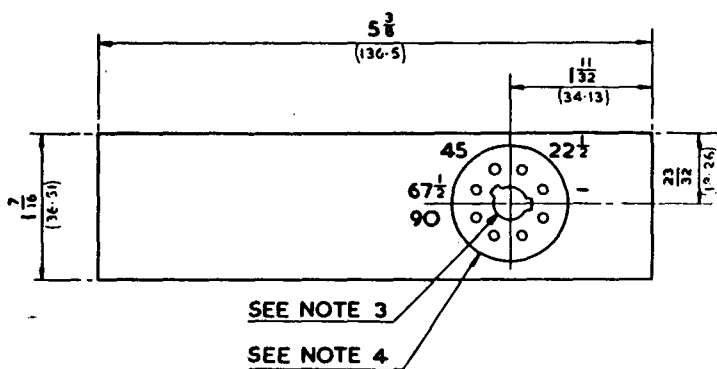

WIRING DIAGRAM

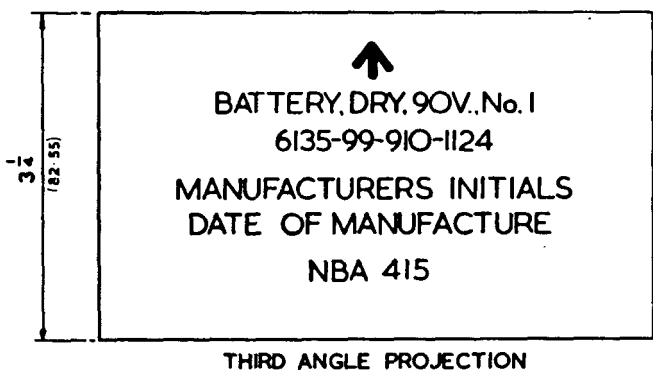
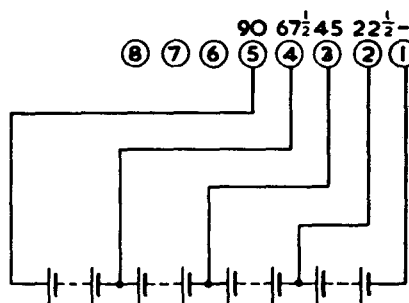

- NOTES:
1. ALL DIMENSIONS ARE IN INCHES WITH EQUIVALENTS, AND SHALL INCLUDE THICKNESS OF MICRO CRYSTALLINE WAX COATING.
 2. UNLESS OTHERWISE SPECIFIED ALL TOLERANCES ARE $\pm \frac{1}{16}$ (1.59)
 3. TOLERANCE ON ORIENTATION OF SOCKET IS $\pm 2.5^\circ$.
 4. DIAMETER OF HOLE IN OUTER CONTAINER IS $1\frac{1}{8}$ (28.58) MIN^m SOCKET SHALL BE RECESSED NOT MORE THAN $\frac{3}{32}$ (2.38) BELOW SURFACE OF CONTAINER WHEN MATING PLUG IS INSERTED.
 5. SOCKET SHALL MATE EFFICIENTLY WITH PLUG PINS $\frac{5}{16}$ (7.94) LONG AND PLUG KEY $\frac{1}{2}$ (12.70) LONG.



Procurement Executive, Ministry of Defence

Directorate of Standardization

Room 1138, Kentigern House, 65 Brown Street, GLASGOW, G2 8EX

Telephone: 0141-224 2595 (Direct Dialling)

Fax: 0141-224 2503

0141-248 7890 (Switchboard)

Internet e-mail address: t.leaver@dstan.mod.uk

Your Reference :

Our Reference : D/DStan/11/2

Date : 9 November 1998

Removal of Product Qualification Approval

IMPORTANT ANNOUNCEMENT

1. This Standard contains a Product Qualification Approval (PQA) scheme. ⁱMOD policy requires that all PQA schemes are removed from Defence Standards called up in contracts placed after 1st January 1998.
2. Users of this Standard are to contact the Project Manager (PM), Equipment Support Manager (ESM) or Technical Service Authority (TSA) named in the contract or order, to identify whether there is a continuing need for an approvals scheme.
3. ⁱⁱProduct Conformity Certification (PCC) is a risk based process that replaces PQA. Once a risk has been identified PCC can be included as a contract clause. In exceptional circumstances agreement can be sought from AD/Stan for PCC to be included in a Defence Standard.
4. At the next revision of this Standard the PQA scheme will be removed.

T R Leaver
Head of Standards Programme Management
Tel: 0141 224 2595 FAX: 0141 224 2503

ⁱ Defence Council Instruction (General) 197/97; Quality Temporary Memorandum 5/98; Chief of Defence Procurement Instruction CDPI/TECH/250 (draft)

ⁱⁱ PCC is certification that a product meets its specification. When PC is required by the contract, the contractor is responsible for obtaining the necessary PCC. Certification shall be provided from a NAMAS accredited laboratory when appropriate. PCC shall apply where a Risk Assessment has been identified by the PM; ESM or TSA.