Sound Ranging

LT. C.W. BAYLISS, 1/7 WELSH REGT.

TRANSCRIBED : 2011

Abstract

This document is a transcription of a set of notes dating from the Great War, probably 1917, written by Lieutenant Carol William Bayliss. It covers the theoretical training given to officers joining Sound Ranging troops, along with notes on enemy gun specifications and a connection diagram for the SR Recorder in use at the time.

The notes were transcribed to the TexNicCentre editing system and typeset using the Memoir document class for the L^AT_EX typesetter. Diagrams were prepared with the Asymptote diagramming language. The PDF file will be available online at the web site of the Wireless-Set-No19 email list group.

<http://www.royalsignals.org.uk>.

Copyright ©M. Bayliff : 2011

Contents

Foreword	iv
Abbreviations	iv
Explanatory Notes	iv
1. Calculating Position of Gun	1
2. Corrections	2
Temperature	2
Wind	2
Asymptote	5
3. Time of Flight	6
4. Shell Wave	7
5. Shell Wave – Gun Wave Interval	9
6. Notes on German Guns	10
Field Artillery	10
Old Guns	10
Howitzers and Mortars	11
High Velocity Guns	11
Naval Guns	12
7. Ranging on a Hostile Battery	13
Coordinates of Points for Plotting Ellipses	13
Scale for error in line	14
Proof of the Method of Ranging by Ellipses	14
8. Plotting Scales	16
Rapid Method	16
9. Favé Curves – Method of Use	17
10. Diagram of Connections	18

Foreword

Mike Bayliff kindly made available an archive of documents from the army service of his father, Carol William Bayliss, during the Great War. Born in 1894, Mr Bayliss Snr. completed his education at Cambridge University, where he received a degree in Electrical Engineering. During the Great War, he was recruited into Artillery Survey and joining a Sound Ranging troop, ending his service with the rank of Captain.

Included in the archive is an "Army Book 136" notebook with the title *Sound Ranging*, bearing a printer's mark indicating a print date of November 1916, as one of a batch of 300,000. It may therefore be assumed to date from at least 1917. These hand written, pencil notes which have been transcribed to produce this document are assumed to have been made during his training.

The task of transcribing these notes was not entirely simple since although Lt. Bayliss' handwriting was good, there were sections which had evidently been written in a hurry. In addition, to reduce the amount of writing, he omitted many definite and indefinite articles and some pronouns. To assist the modern reader, these were reinserted during the transcription.

Little is known of the training arrangements for sound ranging troops in the Great War. By the later years of the war, the principles were well established and the equipment in use could no longer be considered experimental. No official training manual is known before the 1930s and the contents of Lieutenant Bayliss' note book may provide the explanation. The Notes appear to be a course on the theory of the use of sound for the location and ranging of guns, and sheds interesting and unique light on the methods used.

Also included in the notes is a wiring diagram for the SR Recorder in use at the time. Again, there is currently no direct evidence of the detail of the harp galvanometer/photographic recorder used in the First World War and it is hoped that the interpretation of the diagram presented herein, using modern diagram conventions, will add to understanding of this equipment. It is also worth noting that the archive contains a number of original recorder "films" which will be presented separately and which are thought to be the only extant examples of the SR traces of the time.

I would like to thank Mike Bayliff for his generosity in releasing the archive for publication, to Professor Adam McBride of Strathclyde University for his invaluable assistance with the mathematics and to Chris Jones for proof reading. All remaining errors are entirely mine!

Abbreviations

The following abbreviations, which may be unfamiliar to the modern reader, appear in the notes:

"	The symbol for inches.
×	The symbol for yards. Note also that in some diagrams, the cross symbol is used to mark a point.
M	Microphone positions are normally shown as M_1 , M_6 , etc.
M.R.	Maximum range.
M.V. or m.v.	Muzzle velocity.
T or t	Time of arrival of the gun sounds at the microphones.
V or v	The speed of sound in air, normally taken as 337.6 metres (368.7 yards) per second.

In addition, in the geometrical workings below, expressions consisting of two points represent the distances between those points. Thus, M_1M_2 is the distance between two microphones.

Explanatory Notes

On reading the original Notes it is not always clear what Lt. Bayliss meant. In a few cases, small mistakes appear to have crept in, but the main issues are:

1. Some steps appear to have been omitted. Possibly Lt. Bayliss thought they were unnecessary or self-evident.
2. The significance of some approximations were not stressed but Lt Bayliss would have understood how they affected the calculations.
3. Notation is obviously that used at the time and is in some cases unclear to the modern reader.

In order to assist in the understanding of the Notes, Explanatory Notes have been added at the end of the sections to which they refer and they are set in italic, like this paragraph. Equation numbers of the form (i), (ii), (iii), (iv)... are references to the Explanatory Notes.

The reader is reminded that there are still areas of uncertainty and the editor may well have misinterpreted some elements of the original document.

1. Calculating Position of Gun

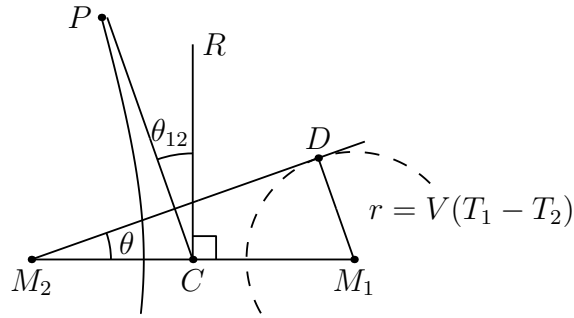

Let gun be at P.

$$M_1P - M_2P = V(T_1 - T_2) \quad (\text{i})$$

Gun lies on parabola [sic]¹ having M_1 and M_2 as focii.

$$\begin{aligned} \text{Let } T_1 - T_2 &= t_{12} \\ \text{and } M_1M_2 &= l_{12} \end{aligned} \quad (\text{ii})$$

CR is right bisector of M_1M_2 .

$$\begin{aligned} \sin \theta_{12} &= \frac{V(T_1 - T_2)}{M_1M_2} \\ &= \frac{Vt_{12}}{l_{12}} \\ &= \frac{t_{12}}{m_{12}} \end{aligned} \quad (\text{iii})$$

where m_{12} is time length as maximum interval:

$$= \frac{l_{12}}{V} \quad (\text{iv})$$

Explanatory Notes.

The hyperbola (not parabola, as in the text) on which the gun P lies and having M_1 and M_2 as focii, has two branches, the one shown to the left of CR and another (not shown) which is the mirror image on the right of CR . Equation (i) should really be:

$$|M_1P - M_2P| = V|T_1 - T_2|$$

The two signs of $T_1 - T_2$ give the two branches of the hyperbola with focii M_1 and M_2 so in Equation (ii), when $t_{12} > 0$, P is on the left branch and when $t_{12} < 0$, P is on the right branch.

In the diagram and Equation (iii), θ_{12} is the angle \widehat{PCR} and is equal to the angle $\widehat{DM_2M_1}$. In the Notes diagram, both of these angles were marked as θ .

Equation (iv) defines m_{12} as a "time length", which simply means the time taken for sound to travel a given length, in this case the distance between M_1 and M_2 . However, it is not clear what is meant by "maximum interval".

¹Clearly this is an error, since a parabola has only one focus. The curve is a hyperbola and this is borne out by the rendering of this method in the Manual of Sound Ranging, 1938. This document is available on the www.royalsignals.org.uk site. – Ed.

2. Corrections

Temperature

Velocity of sound in still air at $10^{\circ}\text{C} = 337.6$ metres per second = 368.7^{\times} per second

$$\begin{aligned} \text{If } V_t &= \text{velocity at } t^{\circ}\text{C} \\ V_{10} &= \text{velocity at } 10^{\circ}\text{C} & (v) \\ \text{then } V_t &= V_{10}\{1 + \alpha(t - 10)\} & (vi) \\ \text{where } \alpha &= 0.0018 \\ \therefore V_t &= 337.6\{1 + .0018(t - 10)\} \end{aligned}$$

Therefore correction is:

$$\begin{aligned} &+0.18\% \text{ per } ^{\circ}\text{C above } 10^{\circ}\text{C} \\ &-0.18\% \text{ per } ^{\circ}\text{C below } 10^{\circ}\text{C} \end{aligned}$$

Explanatory Note.

There appears to have been a mistake here. In the original, Equation (v) defines V_0 as the velocity at 0°C and V_0 appears again in Equation (vi). The calculations make it clear that the temperature should have been 10°C .

Wind

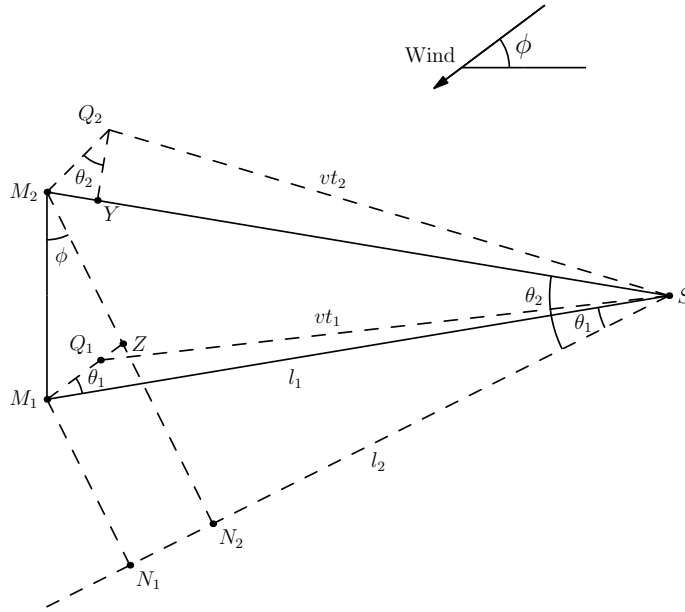

Let velocity of wind = w , making angle ϕ with right bisector of M_1M_2 .

$$\begin{aligned} \therefore \delta T &= \frac{w}{V} \cdot m \sin \phi \\ &= (t_1 - t_2) + \frac{w}{V} \cdot \frac{M_1Z}{V} \\ &= (t_1 - t_2) + \frac{w}{V} \cdot M_{12} \sin \phi \end{aligned}$$

The effect of wind is to decrease time from S to M_2 by $\frac{SM_2}{V} - t$.

$$\begin{aligned} &= \frac{M_2Y}{V} \\ &= \frac{w}{V} \cdot t_2 \cos \theta_2 \\ &= \frac{w}{V} \cdot \left\{ \frac{l_2 \cos \theta_2}{V} \right\} \end{aligned}$$

The velocity of sound (relative to the ground) along GM_1 is $V + \omega \cos \theta_1$ where θ_1 is the angle between GM_1 and the wind direction, so that with the wind, T_1 is reduced to

$$\frac{GM_1}{V + \omega \cos \theta_1}$$

and a correction

$$\frac{GM_1}{V} - \frac{GM_1}{V + \omega \cos \theta_1}$$

must be added to the actual time to get T_1 , the time with no wind and similarly, a correction

$$\frac{GM_2}{V} - \frac{GM_2}{V + \omega \cos \theta_2}$$

must be added to the observed time over GM_2 to get T_2 .

To obtain the corrected time interval ($T_2 - T_1$), the quantity actually measured, the difference between the two corrections must be added to the observed interval. This correction is known as δt_{21} and is given by

$$\delta t_{21} = \left(\frac{GM_2}{V} - \frac{GM_2}{V + \omega \cos \theta_2} \right) - \left(\frac{GM_1}{V} - \frac{GM_1}{V + \omega \cos \theta_1} \right)$$

This can be considerably simplified:

$$\begin{aligned} \frac{GM_2}{V} - \frac{GM_2}{V + \omega \cos \theta_2} &= \frac{GM_2 \omega \cos \theta_2}{V^2 + \omega V \cos \theta_2} \\ &\doteq \frac{GM_2 \omega \cos \theta_2}{V^2} \end{aligned}$$

very nearly, since ω is always small compared with V .

$$\begin{aligned} \text{Now } \cos \theta_2 &= \frac{O_2 M_2}{GM_2}, \text{ so that } \frac{GM_2}{V^2} \omega \cos \theta_2 = \frac{O_2 M_2}{V^2} \omega. \\ \text{Similarly } \frac{GM_1}{V^2} \omega \cos \theta_1 &= \frac{O_1 M_1}{V^2} \omega. \end{aligned}$$

and the wind correction (δ_{21}) is

$$\begin{aligned} \delta_{21} &= \frac{\omega}{V^2} (O_1 M_1 - O_2 M_2) \\ &= \frac{\omega}{V^2} M_2 N \\ &= \frac{\omega l}{V^2} \cos \theta \end{aligned}$$

where l is the length of the sub-base $M_1 M_2$ and θ is the angle the wind flow makes with the sub-base.

Asymptote

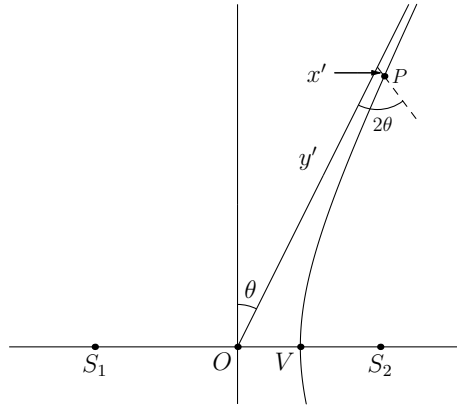

The equation of the hyperbola is: $PS_1 - PS_2 = l \sin \theta$

where $l = S_1 S_2$

and $\sin \theta = \frac{Vt}{l}$

Referred to its asymptote: $x'y' = \frac{l^2}{16}$

It is required to find how far the point P is from the asymptote, or to find what time interval is to be added to the observed time to make the asymptote pass through P .

For point P :

$$x' = \frac{l^2}{16y'} = \frac{l^2}{16r} \quad (\text{vii})$$

r being the distance of P from O .

The perpendicular distance of P from the asymptote

$$\begin{aligned} &= x' \sin 2\theta \\ &= \frac{l^2 \sin 2\theta}{16r} \\ d\theta &= \frac{l^2 \sin 2\theta}{16r^2} \\ \sin \theta &= \frac{Vt}{l} \\ \therefore \cos \theta d\theta &= \frac{V dt}{l} \\ \therefore dT &= \frac{l \cos \theta \cdot d\theta}{V} \\ &= \frac{l \cos \theta}{V} \cdot \frac{l^2 \sin 2\theta}{16r^2} \\ &= \frac{l^2 \cos^2 \theta}{8r^2} \cdot t \\ &= \frac{l^2 t}{8r^2} \left(1 - \frac{V^2 t^2}{l^2}\right) \\ \text{or} &= \frac{1}{2} t \cdot \frac{c^2}{r^2} \cdot \left(1 - \frac{t^2}{m^2}\right) \end{aligned}$$

where $c = \frac{1}{2}l$ and

$c^2 = \frac{1}{4}l^2$ and

$m = \frac{l}{V}$

Explanatory Notes.

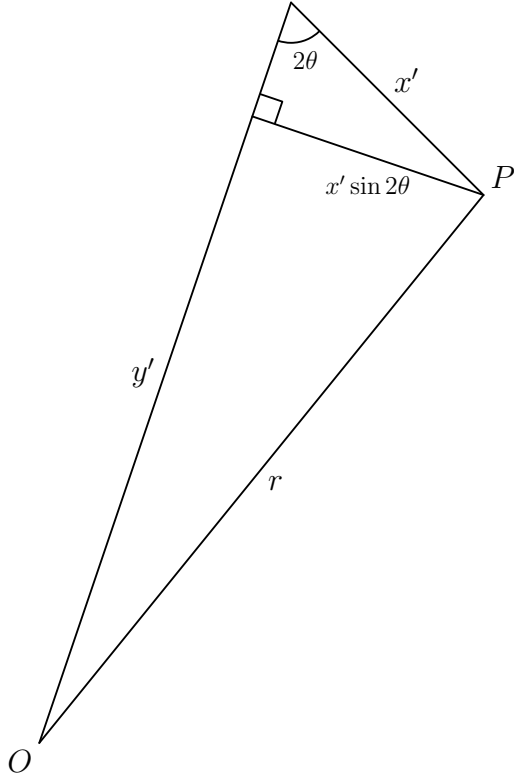

This section seeks to explain the correction required when using the asymptote method for the location of guns, as described in the first section of the Notes. The error is the length x' , the distance between the actual gun position on the hyperbola and the position on the asymptote found from the time interval. The figure to the left expands the diagram in the Notes by exaggerating the error considerably, but it should explain the situation better.

The key to this is Equation (vii) which was incorrectly shown in the original with a y rather than y' . It obviously comes from the equation

$$x'y' = \frac{l^2}{16}$$

but the derivation of this is not shown. It turns out (after a great deal of trigonometry and algebra) that it comes from the definition of the asymptotes, which are generally rendered as

$$y = \pm x \cot \theta$$

but using the substitutions

$$x' = \frac{x \cos \theta + y \sin \theta}{\sin 2\theta}$$

and

$$y' = \frac{x \cos \theta - y \sin \theta}{\sin 2\theta}$$

Returning to Equation (vii) and the diagram above, by Pythagoras

$$r = \sqrt{(x' \sin 2\theta)^2 + (y')^2}$$

Because x' will always be very much smaller than y' , r can be taken as approximately equal to y' . From Equation (vii) therefore, the error x' is equal to the square of the sub-base length divided by sixteen times the distance to the gun. In the Great War, the error might have been individually calculated but by 1937 lookup tables were used to determine the correction to be used.

3. Time of Flight



Suppose we have a gun at G, its burst at B and a microphone at M.

Let the microphone get gun report at time T_g .

Let the microphone get burst at time T_b .

Report takes time $\frac{GM}{V} = t_g$ to reach the microphone.

Burst takes time $\frac{BM}{V} = t_b$ to reach the microphone.

\therefore gun fired at time $T_g - t_g$ and shell burst at time $T_b - t_b$.

$$\begin{aligned} \therefore \text{Time of flight} &= (T_b - t_b) - (T_g - t_g) \\ &= (T_b - T_g) + (t_g - t_b) \end{aligned}$$

4. Shell Wave

As the shell moves in its trajectory, spherical sound waves radiate from its consecutive positions. If its velocity is less than that of sound, as is the case with all howitzers, the position of the wave from a point S_1 , at any time, will lie entirely within the simultaneous position of the wave from a previous point S_2 on the trajectory. The sound of S_1 will reach S_2 before the shell reaches S_2 , so that an observer will hear the shell as it moves in the trajectory, as a continuous series of simple spherical sound waves.

If, however, the shell is moving faster than sound, as is the case with the initial part of the trajectory of all high velocity guns, the shell will have reached S_2 before the the noise of S_1 has reached S_2 . Hence the position of the spherical wave from S_2 , at any time, is in front of the simultaneous position of the wave from S_1 , although formed later. The simultaneous positions of the spherical waves from the adjacent points S_1 and S_2 on the trajectory intersect in a circle and any observer situated on this circle will hear the noise of S_1 and S_2 at the same time.

Now if at any time t after the firing of the gun, we consider the simultaneous positions of the spherical waves radiating from the consecutive positions of the shell as it moves in the trajectory, then if the positions of the shell be taken close enough together, the intersections of each simple wave with the previous wave will form a continuous surface. This surface gives the position, at the time t after the firing of the gun, of the compound wave formed by the motion of the shell.

This wave is called the “*onde de choc*” or “*shell wave*”². It is similar in form to the wave of a ship as it moves through the water; it is sharper the higher the velocity of the shell, whereas the intensity depends on the capacity of the shell for retaining its velocity and hence upon the weight and shape of the shell.

The shell wave is bounded by a cone, vertex the gun, generators the straight lines joining the gun to the points of intersection of the gun wave and shell wave. It is greatest in intensity on the tangent to the trajectory and diminishes to zero on approaching the generators of the bounding cone. In geometrical language, the shell wave may be defined as

The envelope of the simultaneous positions of the simple spherical waves from consecutive positions of the shell in its trajectory. The wave is real, coincident with the gun wave, or imaginary, according as the *m.v.* of the shell is greater than, equal to or less than the velocity of sound.

In the case of prematures, or a very high velocity gun firing at short range, the velocity of the shell may not have fallen below that of sound when the shell bursts. In this case, the shell wave is not completely formed when the shell bursts and consequently as the wave moves forward its apex will open outwards. We should say then that the shell wave is only heard between two cones, one vertex the gun, axis the line of fire, semi-vertical with angle $\cos \frac{v}{u_0}$ (see later), the other vertex the burst, axis line of fire, semi-vertical with angle $\cos \frac{v}{u_1}$ (where $u_0 = MV$ and $u_1 =$ velocity at the time of burst).

On the generators of the first cone, shell wave coincides with gun wave, on the generators of the second cone, shell wave coincides with burst. Inside the second cone the shell wave is not formed and we have burst coming before gun wave.

— — — —

The shell wave is bounded by a cone, vertex the gun, axis initial tangent to the trajectory, semi-vertical angle β_0

$$\begin{aligned} \text{where } \cos \beta_0 &= \frac{v}{u} \\ \text{when } u_0 &= MV_1 \\ \text{and } v &= \text{velocity of sound} \end{aligned}$$

²The literal translation is “shock wave” or alternatively the “sonic boom” – *Ed.*

Proof:

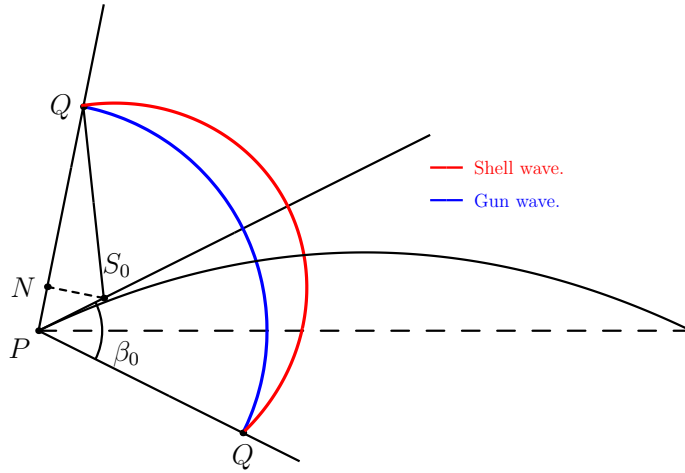

The generators of the bounding cone are the straight lines joining the gun to the intersection of the gun wave, at time t , in the simultaneous spherical wave from point S_0 , where PS_0 is indefinitely small, i.e. the straight line PQ joining the gun to the intersection of the sphere, centre the gun, radius vt , and a sphere centre S_0 , radius $v(t - \delta t)$ where

$$PS_0 = u_0 \delta t$$

and S_0 is on the trajectory, i.e. S_0 is approximately an initial tangent.

Draw $S_0N \perp PQ$.

Then

$$\begin{aligned} NQ = S_0Q &\approx v(t - \delta t) \text{ when } S_0 \rightarrow P \\ \therefore PN &\approx \delta t^2 \\ \therefore \cos \beta_0 &= \frac{PN}{PS_0} \\ &= \frac{v \cdot \delta t}{u_0 \cdot \delta t} \text{ when } \delta t \rightarrow 0 \\ &= \frac{v}{u_0} \end{aligned}$$

On the horizontal plane, the shell wave is heard in front of the gun and between the straight lines intersecting in the gun, angle $2\beta_H$, bisected by projection of the trajectory on the horizontal plane, where

$$\begin{aligned} \cos \beta_H &= \cos \beta_0 \sec \alpha_0 \\ &= \frac{v}{u_0 \cos \alpha_0} \\ &= \frac{v}{u_H} \end{aligned}$$

where α_0 is the angle of fire and u_H is the initial horizontal velocity.

Explanatory Notes.

The inclusion of such a detailed explanation of the characteristics of the shell wave is interesting, as it was not used for sound location for the simple reason that the speed of the shell wave is not known. The wave is the result of the disruption of the air as the shell moves through it and the shell will often be travelling at greater than the speed of sound, at least when fired. If the shell is supersonic when fired, the shell (and the disruption it causes) will travel ahead of the gun wave, as shown in the diagram below. The Gun Wave is shown in blue and the Shell Wave in red.

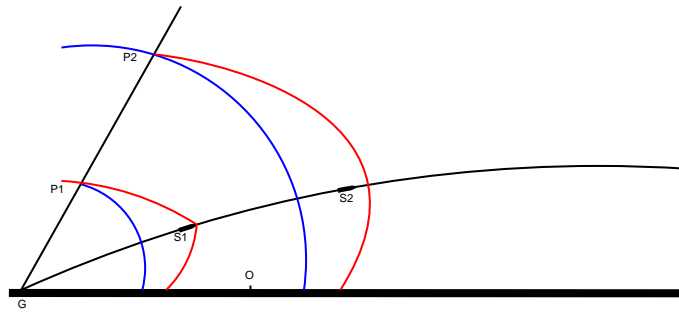

This diagram is probably more obvious than the one in the Notes and is a view at right angles to the line of flight of the shell. *G* is the gun and *S1* is the position of the shell after an interval of time, during which the shell is travelling at supersonic speed. The shell wave is conical, like a bow wave in three dimensions, the apex being more acute, the faster the shell velocity. As the shell slows down, the apex of the shell wave becomes rounder and when the speed has dropped below that of sound, the shell ceases to create a shell wave and the wave already formed will be travelling ahead of the shell. This situation is shown with the shell at *S2*. Note that an observer at *O* will hear the shell wave first, then the gun wave.

While the shell is travelling it is continuously producing a disturbance and the sound this causes at every instant will radiate out as a circular wave front at the speed of sound. All these radiating wave fronts form a surface which continues to radiate outward, with its source travelling along the trajectory of the shell. At some point, the shell velocity drops below that of sound and production of the shell wave ceases, although the wave front surface already produced continues to expand at the speed of sound.

As the gun fires, the gun wave and shell wave are coincident and the gun wave is a single spherical wave front expanding at the speed of sound. The shell wave, as we have seen, is a continuously produced series of spherical wave front and the rearward parts of this will touch the gun wave. The points at which this occurs describe the surface of a cone and, as the Notes indicate, inside the cone both gun and shell waves exist – outside it, no shell wave is formed.

5. Shell Wave – Gun Wave Interval

Time interval between Shell Wave and Gun Wave.

Calibre of Gun	MAX. Secs.	Point when GW & Burst coincide
		Secs.
12 cm.	0.2	0.15
9 cm.	0.35	0.29
7.7 cm.	0.61	0.59
15 cm. H.E.	1.15	0.88
15 cm. Shrapnel	1.38	1.1
10 cm.	1.78	1.48
13 cm. H.E.	5.8	4.5
13 cm. Shrapnel	6.5	3.9

Explanatory Notes.

As already mentioned, the shell wave cannot be used for location, but it can provide information from which gun calibre can be estimated. It turns out that the separation in time for any observer of the gun wave, shell wave and burst are dependant on a number of factors:

- The muzzle velocity of the shell.
- The rate at which the shell slows down in flight.
- The elevation at which the gun is firing.
- The distance of the observer from the gun.

The first two are dependant upon the characteristics of the gun and its ammunition, the third can be inferred from the range over which the gun is firing and the last is known from sound ranging. An experienced observer can infer the gun calibre and ammunition type from the separations of the gun wave, shell wave and burst. It would appear that the table in this section of the Notes is to assist in this operation but there was also a set of graphs known as Bertrand's Graphs which allowed easier estimation of the gun calibre and ammunition type. Bertrand's Graphs are also mentioned in the section on Favé Curves.

6. Notes on German Guns

Field Artillery

7·7cm. Field Gun, 15 lb.

M.V. 1526 ft/sec; 32 grooves; Shell 15 lb.; c = 7·7 cm.; M.R. 9186[×]; Corresponds to 18 pdr.; 4 guns to battery; H.E. and Shrapnel used.; 3 ft. diam. crater; Used as AA gun.

Shell	Fuse
1915 H.E. grey.yellowhead	{ K.Z. 11 Gr. K.Z. 16 m.V.
1915 Gas Shell grey.yellowhead	{ K.Z. 14. K.Z. 16 m.V.
7·7 cm. Long H.E. blue.yellowhead	{ LKZ H.Gr. LKZ 160V LKZ 16 m.V.
7·7 cm. Shrapnel blue	Dopp. Z 96 n/A

10·5cm. Howitzer, 35 lb.

M.V. about 1080 ft/sec; 32 grooves; Shell 35 lb.; c = 10·5 cm.; M.R. 6890[×]; Corresponds to 4·5" howitzer; 3 or 4 gun battery; H.E. or Universal used, rarely shrapnel; 6 to 8 ft crater.

Shell	Fuse
1915 H.E. grey.yellowhead	{ H.Z. 116 H.Z. 05 Gr.
Long H.E. blue.yellowhead	{ H.Z. 16 H.Z. 05 Gr.
Gas Shell blue.yellowhead	{ H.Z. 14 H.Z.16
1916 Shrapnel	H.Z. 05, Schr.

Old Guns

9·cm. Field gun, 16·53 lb.

M.V. 1450 ft/sec; 24 grooves; Shell 16·53 lb.; c = 11·7 cm.; M.R. 7109[×]; Old type of gun, not infrequent. Easily distinguished by low M.V.

Shell	Fuse
H.E. (modern.red)	H.Z. 14 Vst.
H.E. (modern.grey)	GrZ. 14
Shrapnel.blue	{ Dopp.Z.92.Lg.Brl. Dopp.Z.92.K.15

12cm. Gun

M.V. 1280 ft/sec; 30 grooves; Shell 36·38 lb.; c = 12·8 cm.; M.R. 7984[×].

Shell	Fuse
Modern H.E. (red)	H.Z. 14 Vst.
80/92 Shrapnel (red)	Dopp.Z.92

15 cm., Ring Kanone.

15 cm., Large Ring Kanone.

M.V. 1499 ft/sec; 24 grooves; c = 20·0 cm.; M.R. 8312[×].

Shell	Fuse
Modern H.E. (red)	G.R.Gr.Z.14
80/92 Shrapnel (red) } 107 Shrapnel (grey) }	{ Dopp.Z.92 Dopp.Z.92 Lg.Brl. Dopp.Z.92 K.15

15 cm. Long Gun, 90 lb.

M.V. 1624 ft/sec; 36 grooves; Shell 90 lb.; $c = 13.3$ cm.; M.R. 10,718[×]; 2 guns to position; 7ft. craters.

Shell	Fuse
'96 H.E. (blue)	Gr.Z. 04
'92 Shrapnel (blue) } 107 Shrapnel (grey) }	{ Dopp.Z.92 Dopp.Z.92 Lg.Brl. Dopp.Z.92 K.15

21 cm. Ring Kanone, 213 lb.

30 grooves; Shell 213 lb.; $c = 22.5$ cm.; M.R. 10718[×].

Shell	Fuse
'06 H.E. (blue)	Lg.Bd.Z.10
'04 Shrapnel (blue)	{ Dopp.Z.92 Dopp.Z.92 Lg.Brl. Dopp.Z.92 K.15

Howitzers and Mortars**15 cm. Howitzer, 90 lb.**

M.V. 1196 ft/sec; 36 grooves; Shell 90 lb.; $c = 13.3$ cm.; M.R. 9296[×]; Corresponds to 6" How.; 2 guns to Position; Used for counter battery work; Powerful burst; Gas shell and H.E. used.

Shell	Fuse
1912 H.E. (grey, black or blue head) } Gas shell T or K (grey, black head, or black T or yellow K) }	Gr.Z.04
Gas shell (grey, 2 blue rings)	Gr.Z.14 n/A
1914 H.E. (grey, black head)	Gr.Z.14

21 cm. Mortar

64 grooves; $c = 10.5$ cm.; Corresponds to 8" How.; 2 types of H.E. used; Armour piercing with base fuse, 25ft. crater; Ordinary 12ft. crater.

Shell	Fuse
1896 n/A H.E. (grey) 1914 A.H.E. (red) }	KZ.Bd.Z.10
1914 H.E. (grey, black head, blue nose) }	{ Gr.Z.04 GR.Z.04/14

High Velocity Guns**10 cm. Gun, 40 lb.**

M.V. 1930 ft/sec; 32 grooves; Shell 40 lb.; $c = 10.5$ cm.; M.R. 11,811[×]; Corresponds to 4.7" gun; 6 ft. crater; Lighter gun and shell than 60 pdr.

Shell	Fuse
1896 H.E. (blue)	Gr.Z.04
H.E. (yellow, blue head)	Dopp.Z.92.f.10.K
1914 A.H.E. (grey)	H.Z.14.Vst.
1914 H.E.(red)	H.Z.14.Vst.
1896 Shrapnel (blue)	{ Dopp.Z.92.f.10.cmK Dopp.Z.92.K.15

13 cm. Gun, 88 lb.

M.V. 2280 ft/sec; 36 grooves; Shell 88 lb.; $c = 12.0$ cm.; M.R. 15,148[×]; Heavier shell and higher M.V. than 60 pdr.; Not so good as 6" Mk VII; 8 ft. craters.

Shell
 H.E. (blue)
 1914 H.E. (grey)
 Shrapnel
 Incendiary Shell

Fuse
 Lg.Bd.Z.10
 Gr.Z.14
 Dopp.Z.92.f.10cmK
 Brd.Gesch.Lg.Bd.Z.10

Naval Guns

10.5 cm. Naval Gun, 35.3 lb.

M.V. 2750 – 3000 ft/sec; grooves; Shell 35.3 lb.; Corresponds to 4" anti-torpedo gun.

15 cm. Naval Gun, 101.4 lb.

M.V. 2750 – 3000 ft/sec; 44 grooves; Shell 101.4 lb.; c = 11.0 cm.; M.R. 18,500^x; Corresponds to 6".

Shell
 H.E. (yellow)
 H.E. with false cap (yellow)

Fuse
 Dopp.Z.S/43
 Percussion fuse.

21 cm. Naval Gun, 255.5 lb.

M.V. 2750 – 3000 ft/sec; 60 grooves; Shell 255.5 lb.; c = 10.5 cm.; Corresponds to 7.5".

Shell
 H.E. with false cap (yellow)

Fuse
 Spgr.m.K

24 cm. Naval Gun, 418.9 lb.

M.V. 2750 – 3000 ft/sec; 72 grooves; Shell 418.9 lb.; c = 11.0 cm.; M.R. 27,500^x (?); Corresponds to 9.2".

Shell
 H.E. (yellow) }
 H.E. with false cap (yellow) }

Fuse
 Spgr.m.K

28 cm. Naval Gun, 661.4 lb.

M.V. 2750 – 3000 ft/sec; Shell 661.4 lb.; Corresponds to 12".

38 cm. Naval Gun, 1675.5 lb.

M.V. 2750 – 3000 ft/sec; Shell 1675.5 lb.; Corresponds to 15".

Shell
 H.E. with false cap (?)

Fuse
 ?

7. Ranging on a Hostile Battery

Suppose a German gun fires and several rounds are recorded. The time intervals between the arrivals of the sound at the microphones are measured, any zero of time being taken. Suppose now that one of our batteries fires at the hostile battery, and that the burst of the shell is also recorded.

If this shell bursts very close to the enemy gun, the time intervals will be about identical with those given by the enemy gun itself. If the shell bursts to the right of the enemy battery, the microphones on the R.H. side of the base will get the sound sooner than normal as compared with those of the L.H. side and *vice versa*. This is made use of as follows.

A graph is made on a piece of squared paper. Six vertical lines are drawn, one for each microphone position, and a seventh line to represent the line of fire from our battery. A horizontal straight line is taken as zero. The difference between the time interval for the gun (the ideal time interval) and that for the burst, is plotted for each microphone on its corresponding vertical line.

If the burst were a direct hit, all the points so plotted would lie on a horizontal straight line. If the burst is to the right, the points on the R.H. side are low and those on the L.H. side are high, and the line will slope down to the right and *vice versa* for L.H. bursts. If the burst is over, the points for the centre microphones are high, those of the flank are low, and the points lie on a curve hollow downwards, and *vice versa* for a short burst.

If the vertical straight lines corresponding to the microphones are always plotted to the same convention and time differences to the same scale, the amount of slope for a burst which is $100\times$ + or - is always the same. It is therefore possible to draw a series of curves on transparent paper, and by fitting them over the plotted points, to say how much the round is right or left and + or -. Ready-drawn curves are supplied to the sections for ranging. In order to use these curves, the graph is drawn as follows:

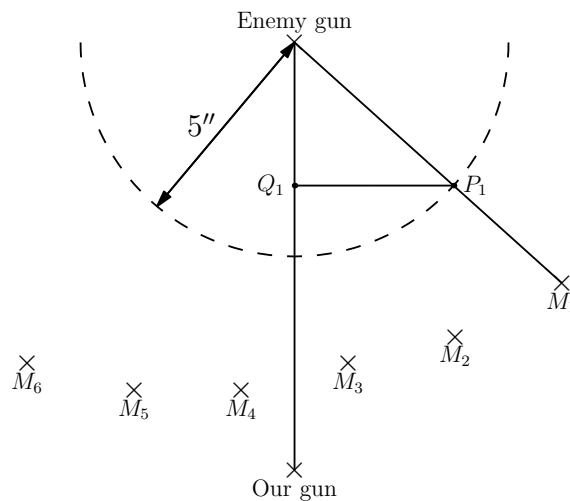

Paper squared in inches and tenths is used. A vertical straight line is drawn to represent the line of fire. The position of the hostile gun and the position of the battery which is to range on it are marked on the map board (or on a piece of tracing paper). Lines are drawn joining the hostile gun to the battery and to the microphones. A circle of 5" radius is drawn around the hostile battery position. On drawing the graph, No 1 line is drawn to the right of the line of fire and a distance P_1Q_1 from it, and so on for the other microphones. The time interval differences are plotted so that $1'' = \frac{1}{10}$ second.

Coordinates of Points for Plotting Ellipses

	x=	0.5	1.0	1.5	2.0	2.5	3.0	3.5	4.0	4.5	5.0
50 \times error	y=	0.007	0.022	0.062	0.114	0.182	0.271	0.388	0.544	0.766	1.36
100 \times error	y=	0.013	0.045	0.228	0.125	0.364	0.543	0.776	1.087	1.531	2.72
150 \times error	y=	0.021	0.068	0.187	0.342	0.547	0.812	1.164	1.631	2.297	4.08
200 \times error	y=	0.027	0.091	0.250	0.456	0.729	1.086	1.552	2.175	3.062	5.49

All figures in inches.

Curves below axis of x indicate + error in range.

Curves above axis of x indicate - error in range.

Scale for error in line

Drawn parallel to x axis through points: $(x = 0, y = 1 \cdot 840)$ and $(x = 0, y = -1 \cdot 840)$ then $1'' = 100^\times$

Proof of the Method of Ranging by Ellipses

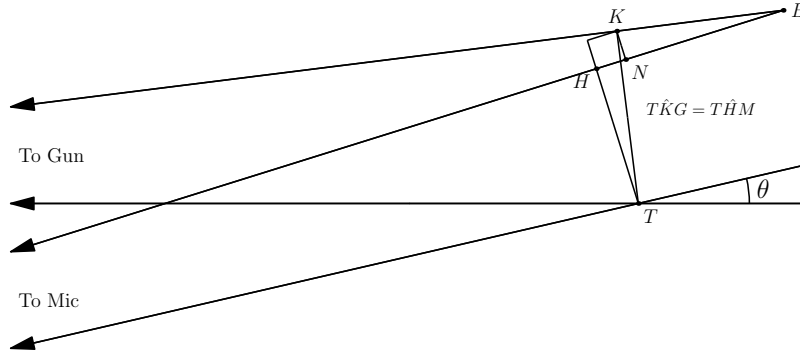

Let G be the position of the gun.
 Let T be the position of the target.
 Let B be the position of the burst.
 Let M be the position of the microphone.
 Let KB be the error in range = r
 Let TK be the error in line = l
 Let GT and GB may be considered parallel.
 Let MT make angle θ with GT .
 Draw $TH.TK$ perpendicular to $MB.GB$.
 Draw KN perpendicular to MB .
 Let t_T be the time to target on standard film at Microphone M.
 Let t_B be the time to burst on standard film at Microphone M.

$$t_T = \frac{MT}{v} - \text{constant}$$

$$t_B = \frac{MB}{v} - \text{constant (different)}$$

$$G\hat{B}M = H\hat{T}K = M\hat{T}G = \theta$$

$$\delta t = t_B - t_T$$

$$= \frac{MB - MT}{v} - \frac{c}{v}$$

c is constant depending on the zero of the two films.

$$= \frac{HB}{v} - \frac{c}{v}$$

$$= \frac{HN + NB}{v} - \frac{c}{v}$$

$$= \frac{l \sin \theta + r \cos \theta}{v} - \frac{c}{v}$$

Hence on graph points P' are:

$$\begin{cases} y = b.\delta t = \frac{b}{v}(P \sin \theta + r \cos \theta) - K \\ x = a \sin \theta \end{cases} \quad (1)$$

If there is no error in range, i.e. $r = 0$, (1) becomes:

$$y = \frac{bl}{av} .x - K \quad (2)$$

This is a straight line where the slope is $\frac{bl}{av}$.

If there is no error in line, i.e. $l = 0$, (1) becomes:

$$(y + K)^2 = \frac{b^2 r^2}{v^2} \cdot \left(1 - \frac{x^2}{a^2}\right)$$

i.e. the ellipse

$$\frac{x^2}{a^2} + \frac{(y + K)^2}{\frac{b^2 r^2}{v^2}} = 1 \quad (3)$$

The centre of this ellipse is on the axis of y . One semi axis is parallel to the axis of x and of length a . The other is along the axis of y , of length $\frac{br}{v}$, i.e. proportional to r .

If there is an error in range and line, (1) becomes:

$$\left(y - \frac{bl}{av}x + K\right)^2 = \frac{b^2 r^2}{v^2} \left(1 - \frac{x^2}{a^2}\right)$$

i.e. the ellipse

$$\frac{x^2}{a^2} + \frac{\left(y - \frac{bl}{av}x + K\right)^2}{\frac{b^2 r^2}{v^2}} = 1 \quad (4)$$

This is an ellipse in which

$$\left. \begin{array}{l} x = 0 \\ y = \frac{bl}{av}x + K \end{array} \right\} \text{ are conjugate diameters,}$$

i.e. the tangent at the point where the axis of y cuts the ellipse is parallel at line $y - \frac{bl}{av}x = 0$, where slope is $\frac{bl}{av}$. If the error in line is small, the ellipse (4) is practically identical with ellipse (3). Hence if the ellipse

$$\frac{x^2}{a^2} + \frac{y^2}{\frac{b^2 r^2}{v^2}} = 1$$

be laid on the graph, keeping the extremity, B , of the axis originally along the axis of y , on the axis of y , the error in line is given by the slope of the tangent at B , i.e. the tan of the angle between the principal axis through B and the axis of y in the graph. The error in range is given by the length of the principal semi-axis through B .

It is usual to take $a = 5''$ and $\frac{1}{10}''$ to represent $\frac{1}{100}$ second i.e. $b = 10''$ per second.

In this case, the slope of the tangent at B is

$$\frac{bl}{av} = \frac{10}{5} \times \frac{l}{369 \cdot 2} = \frac{2l}{369.2}$$

where l is measured in yards. The semi-axes of the ellipse are

$$\begin{aligned} a &= 5'' \\ \frac{br}{v} &= \frac{10r}{369.2}'' \end{aligned}$$

where r is measured in yards. $\frac{br}{v}$ is positive, i.e. the ellipse is convex upwards when the error in range is positive.

Explanatory Note.

In the paragraph after Equation (3); the second y was shown incorrectly as an x . The original paragraph was:

“The centre of this ellipse is on the axis of y . One semi axis is parallel to the axis of x and of length a . The other is along the axis of x , of length $\frac{br}{v}$, i.e. proportional to r .”

8. Plotting Scales

Fix the microphone positions by coordinates from fixed axes. Centres of bases and points on right bisectors at distances of 10,000 metres from base centres are plotted accurately. The right bisector gives the direction of zero graduation on scale. The direction of any graduation corresponding to time t is inclined to the right bisector at $\sin^{-1} \frac{t}{m}(\theta)$. Not accurate enough to plot with protractor.

Draw a straight line parallel to the base at (say) 10,000 metres from the base. Let this straight line meet the right bisector at O . From \sin and \tan tables obtain values of $\tan \theta$ for times t . From O mark off along the parallel line the distance $OP = 10,000 \tan \theta$ metres, then the straight line joining this point to the centre of the base gives the direction of graduation for time t . Graduations should be marked this way as far as possible.

When $\tan \theta$ becomes too large, draw a straight line perpendicular to the base at (say) 10,000 metres from the centre of the base. Let this line meet base produced at O' . From O' lay for $O'P = 10,000 \cot \theta$, along line perpendicular to the base. The straight line joining the centre of the base to P gives the direction of graduation.

Rapid Method

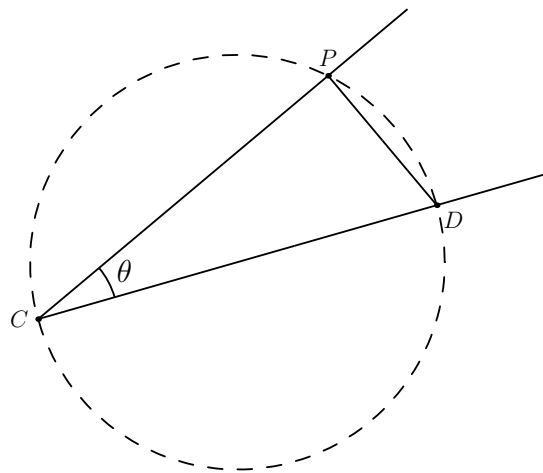

From the centre of base C cut off [sic] length CD along the right bisector equal to m on a convenient scale (say 10cm = 1 second). On CD as a diameter, describe a circle. From D cut off chord $DP = t$ on the same scale as $CD = m$. The CP gives the direction of graduation corresponding to t .

Not to be use for values of $t > \frac{4}{5}m$.

9. Favé Curves – Method of Use

Let M be microphone position.

Let E be burst position.

Let P be gun position.

Let shell wave reach microphone at time t .

Let burst wave reach microphone at time t' .

Time that shell burst is $t' - \frac{ME}{v}$.

Let the interval between shell burst and the time the shell wave reaches the microphone be I .

$$\therefore I = t - t' + \frac{ME}{v}$$

Let I be $(\tau + \tau')$ where τ is an integral and $-.5 < \tau < .5$.

On tracing paper we mark the positions of burst B and the microphones. With M as centres, radius $v\tau'$ describe circles.

From Bertrand's graphs and the shortest $t - t'$ interval with an idea of the calibre of the gun, we can get an approximate range of the gun.

Select two consecutive Favé graphs so that for the first, the circles around M_1 and M_2 are made to touch the curves labelled τ_1 and τ_2 and B is made to lie on the line joining the gun to the burst, B is on a different side of E than it would be if the tracing were similarly placed on the second graph.

Mark the position of burst E on the tracing for each graph (E_1 and E_2) and also the direction of the line joining the gun to the burst. Let p_1 and p_2 be ranges of selected graphs.

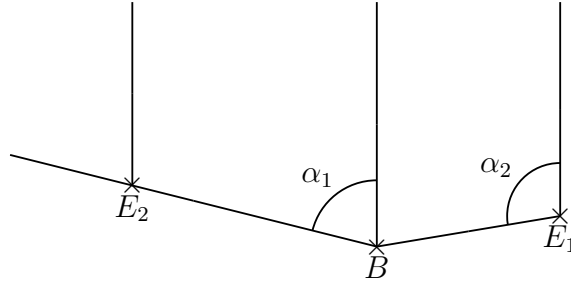

E_1B is f_{in} of range p , which vanishes for the exact range. Hence if the interval between ranges is close enough we will get a close enough approximation to the true range by admitting that the f_{in} varies directly as the variable. Then if p_r is the exact range,

$$\begin{aligned} BE_1 &= f(p_r - p_1) \\ &= a(p_r - p_1) \\ E_2B &= a(p_2 - p_r) \\ \therefore \frac{BE_1}{E_2B} &= \frac{p_r - p_1}{p_2 - p_r} \\ \frac{BE_1}{E_2B} &= \frac{BE_1}{BE_1 + E_2B} \end{aligned}$$

Similarly for line

$$\frac{\alpha_r - \alpha_1}{\alpha_2 - \alpha_1} = \frac{BE_1}{BE_1 + E_2B}$$

Explanatory Note.

This section is relatively obscure without access to Favé Curves. Unfortunately, research has so far failed to find any references to these curves and there is no mention of them in the Manual of Sound Ranging, 1937. All that can be assumed is that this method is for finding the range, but not the bearing, of a gun. The circumstances under which it was used remain unknown.

10. Diagram of Connections

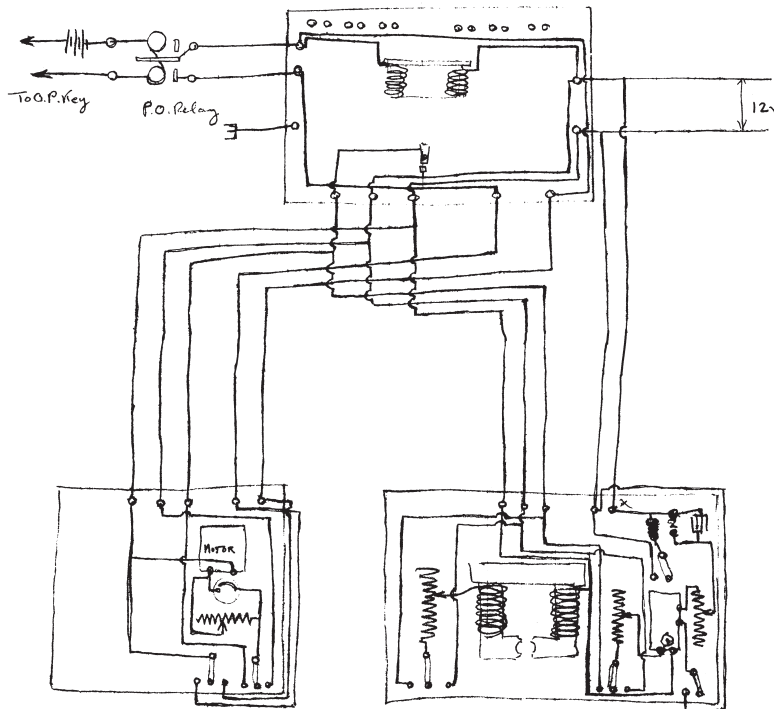

The above diagram from the Notes has been redrawn below using modern diagramming conventions:

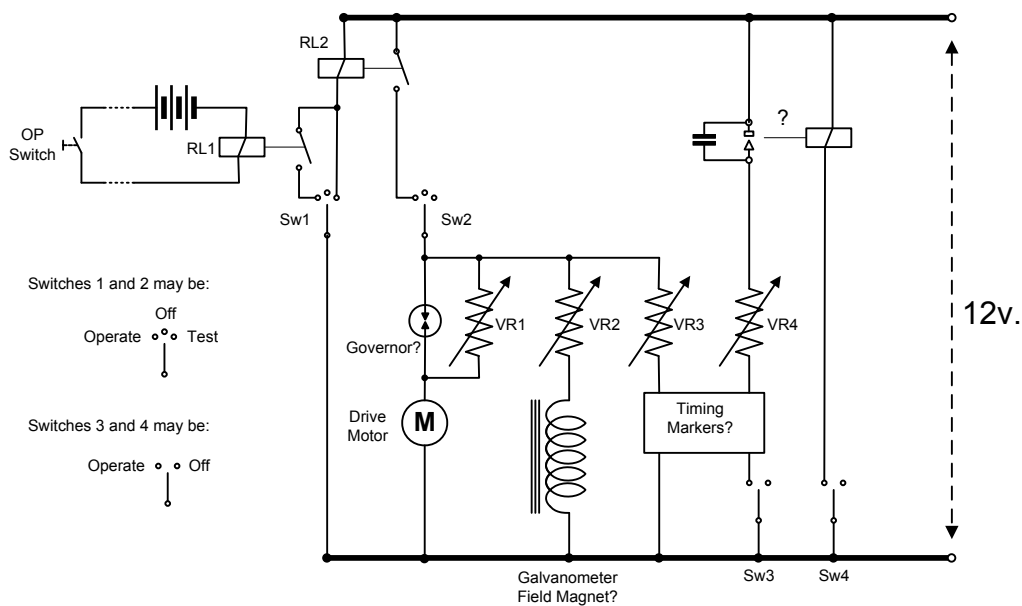

Explanatory Notes.

This section is an interpretation based on information on the Recorder, Sound Ranging, No 1 Mk II from 1933 (National Archive WO279/564). This equipment is a descendant of that used by Lt. Bayliss and may be assumed to share, albeit in an improved fashion, many of the features of the earlier equipment.

The diagram was probably meant to convey the connections between the units making up the system, rather than the detailed circuits or functions. This makes interpretation difficult but we do

know that certain elements were required and this leads to the suggested interpretation, in which several circuit elements can be discerned (but not without some difficulty):

- There was a remote switch at the OP which operated a sensitive relay (labelled “PO Relay” on the original) which in turn operated the recorder. This is relay RL1 and it operated a heavier duty relay (shown as RL2). The OP pressed the button to start the recorder and, unlike later versions, had to continue to press the button until the gun wave passed all the microphones.
- Drive motor. One motor probably operated the whole mechanism through a number of gear trains (this was certainly true of later versions) and we can assume that the item marked “motor” in the original was that motor. What is less certain is the round object shown immediately below the motor on the original diagram. It was initially thought that this was the lamp, but its connection in series with the motor and in parallel with the variable resistor makes this extremely unlikely. It is currently suggested that this may have been some sort of centrifugal governor, which shorted out the resistor until the motor was up to speed.
- VR2 fed an electromagnet with no label in the original diagram. However, the shape of the core suggests that it may have provided the galvanometer’s magnetic field. The galvanometer in the later system had a permanent magnet. However, it does seem the most likely explanation and we must assume that magnetic materials were not then as advanced as they later became.
- The time mark arrangements, possibly vanes in the optical path which produced timing marks on the film. From examples of the traces produced, the marks appear to be at 1 second and 0.1 second intervals and are light lines on the dark background. In later models, these were produced by a disk rotated by an AC motor which was driven by a tuning fork and amplifier. In the original diagram there is a strangely drawn set of contacts and a box in the bottom right, which together have been interpreted as some form of timing mark generator. The coil and contacts have been labelled “?” and could be some form of frequency stable vibrator. Whatever is in the box, it may be assumed to have at least produce the seconds marks, since there is an “S” on it (not discernible on the copy but visible on the original).
- An Off/Operate/Test switch. The reader will see that the four switches perform a similar function and they could possibly have been ganged, although there is no evidence of this in the original diagram.

It is to be hoped that further evidence on the Great War recorder will emerge but in the mean time, the above speculations will have to suffice.